

(TSL) PHOENIX

tsloutdoor.com

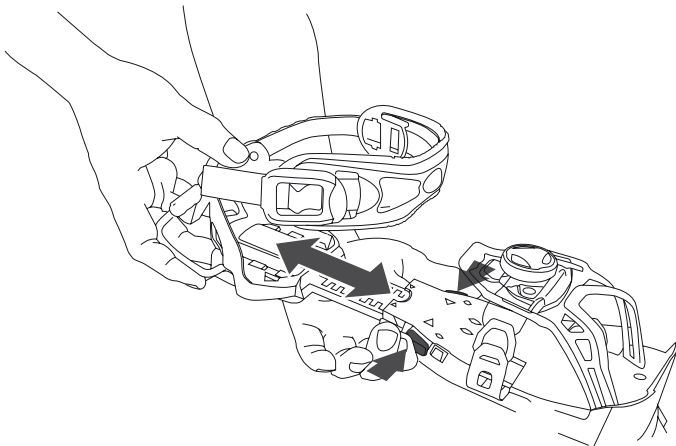
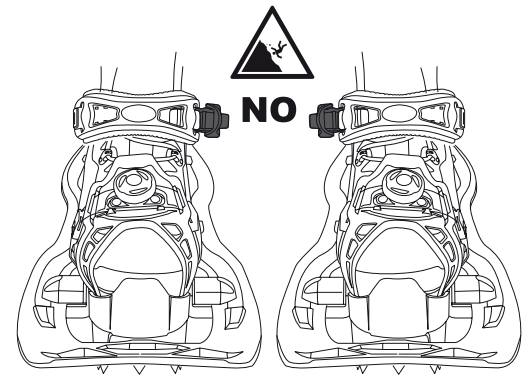
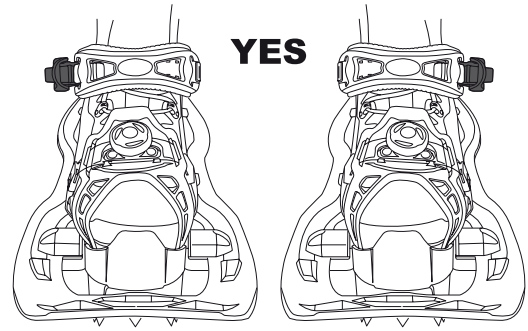

LOCK ADJUSTMENT

PRESET ANKLE

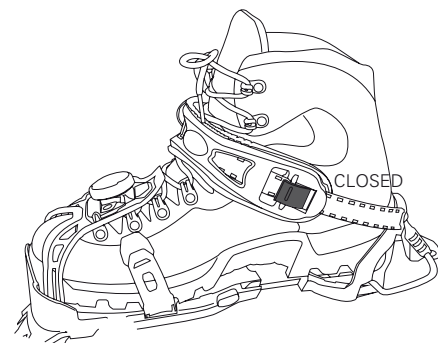
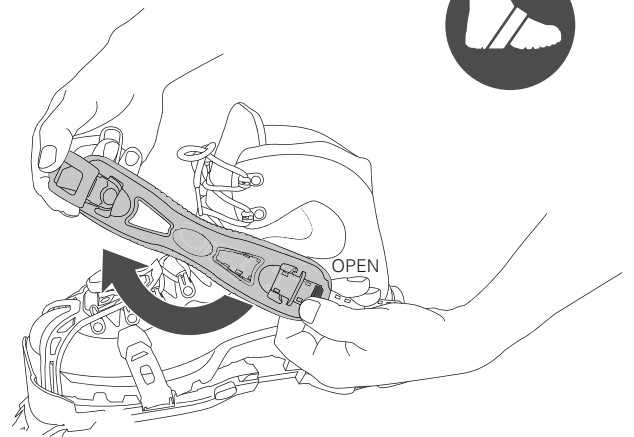

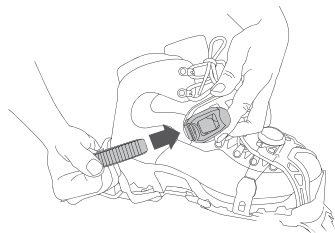

ON

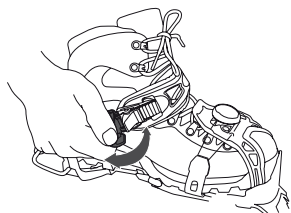

ON

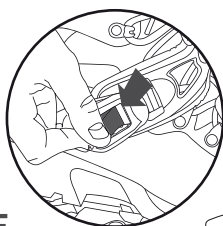
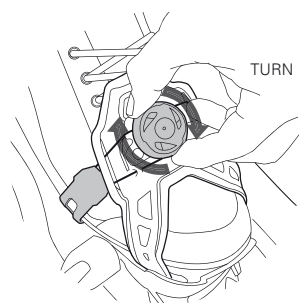
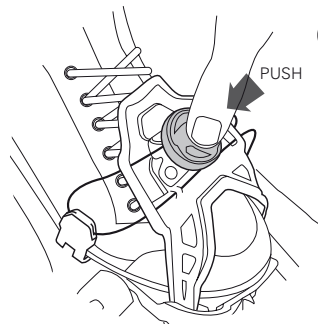

OFF

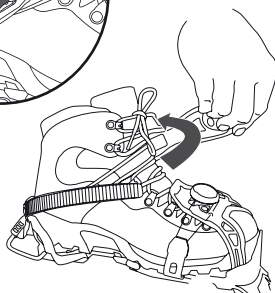

OFF

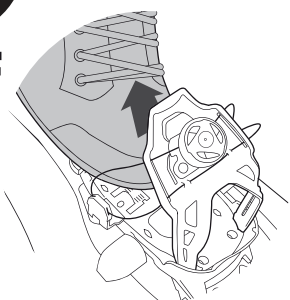
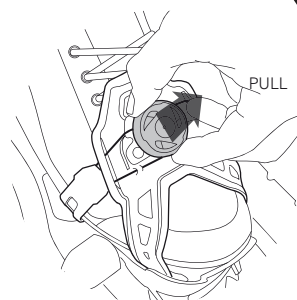

easy ascent
SSAS version

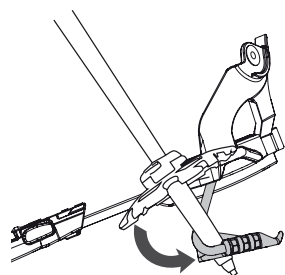
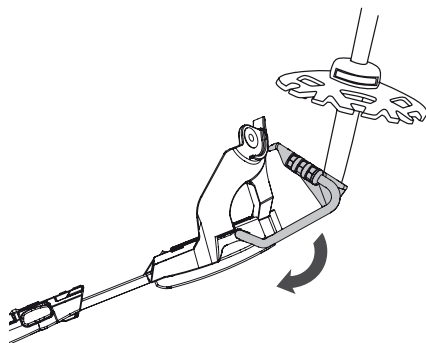

CODE OF CONDUCT

1. SECURITY

- I ask about any dangerous areas; winter paths are very different from summer paths
- I choose an itinerary suitable for my physical condition. I inquire about the route chosen and I do not go alone too far and not for too long
- ➔ I keep updated on weather conditions and avalanche risk

2. EQUIPMENT

- I use suitable equipment and clothing in good condition. I bring hot drinks and food
- I use safety and orientation equipment suitable for the difficulty of my trek (map, pharmacy, survival blanket, rope, «ARVA», snow probe, shovel...)

3. ENVIRONMENT

- Fauna: do not follow animal tracks
- Flora: young trees and vegetation
- Keep sites clean and quiet: one track is enough for a whole group

4. OTHERS

- I leave ski slopes to skiers, I inquire about winter activity regulations, I respect other users' need for quietness

5. ADVICES

- Mountain guides, Ski patrols, local police forces, civil security, local weather forecast Park rangers, Natural Reserve Guards, etc

- ➔ Our snowshoes have been designed for use in areas that are safe and close to residential areas. They are not intended for alpinism use. TSL cannot be held liable in the event of non-compliance or disregard of the intended use.
- ➔ In case of any accident, protect the victim, keep her warm, reassure him or her and call for help. Dial 112 (Europe).

WARRANTY

TSL's products are guaranteed against any operation defect resulting from any material, manufacturing or designing defect subject to the following provisions. This warranty applies for 2 years after the delivery of the product in accordance with article L. 217-4 of the french Consumers' Code. Replacement parts available, 5 years. Manufacturing defects are covered subject to normal maintenance and normal use (hiking).

The warranty shall not apply :

- If the product has been repaired or changed by buyer or third parties appointed by either of these latter.
- If it is for parts made by seller's sub-contractors or suppliers, in which case the sub-contractor's or supplier's warranty applies.
- If the defective operation results from negligence or imprudence on buyer's part.
- If the defective operation results from force majeure or an outside fact.

When a guaranteed defect is found by the buyer, buyer should send a complaint with the proof of purchase, to the seller, by registered mail with acknowledgement of receipt within 45 days of the date on which the defect was found. Under the warranty the seller will replace any part found to be defective by his technical department, free of charge and promptly. This warranty applies in all countries regardless of the country where the product was purchased and regardless of where the damage occurs. In addition some agreements between TSL and its retailers may depart from this rule based on legislation on non-EU countries.



PO BOX 962
Williston, VT 05495 - USA
Tel : +1 802 660 8232 - Fax : + 1 802 862 1626

tsloutdoor.com